

**SECTION-1**  
**TABLE — A: TIME AND WORK FRAME**

**FOR EXECUTION OF WORK UNDER- PROVIDING RED SAND  
STONE RAMP AT AKBARS TOMB SIKANDRA, AGRA.**

MANUAL BIDS SHALL NOT BE ACCEPTED.

**CRITICAL DATE SHEET**

1.	Date of issue of Tender	15/11/2017
2.	Bid Document Download / Sale Start Date	15/11/2017
3.	Bid Submission End Date	27/11/2017 at 15:00
4.	Date of opening of Financial bid	28/11/2017 at 15:30
5.	Validity of Bid	120 days from the date of opening.

Dear Sir,

1. The Archaeological Survey of India invites Online Bids in the prescribed form under the Single Bid system i.e. Financial Bid for Job work Providing red sand stone ramp at Akbar's Tomb Sikandra Agra.
  2. The system of e-tendering shall be adopted, comprising of the Financial Bid. Document Download: Tender documents may be downloaded from CPPP site <https://eprocure.gov.in/eprocure/app> as per the schedule as given in CRITICAL DATE SHEET. Financial Bid should, inter alia, indicate item-wise price and other commercial / financial terms against the items mentioned in the Tender Documents.
  3. **Bid Submission:**

Applicants/ intending or interested Bidders are invited to submit their online proposal after carefully reading the Request for Proposal (RFP) by providing (a) Financial Bid, clearly mentioning (i) 'Financial Proposal' respectively. Such proposals are to be submitted online within the stipulated date and time as mentioned in the Tender document as given in CRITICAL DATE SHEET.

Bids shall be submitted online only at CPPP website: <https://eprocure.gov.in/eprocure/app>.

Bid documents may be scanned with 100 dpi with black and white option which help in reducing size of the scanned document.
  4. **Earnest Money Deposit:**

The Hard Copy of original instruments in respect of cost of earnest money must be delivered to the SUPERINTENDING ARCHAEOLOGIST, ARCHAEOLOGICAL SURVEY OF INDIA, AGRA CIRCLE AGRA, 22 MALL ROAD, AGRA on or Tender opening date/ time as mentioned in critical date sheet. Tenderer shall likely to be liable for legal action for non-submission of original payment instrument like DD etc. against the submitted Bid.

The offer without EMD will be rejected summarily. EMD is to be supplied by all the bidders except those who are registered with Central Purchase Organization, National Small Industries Corporation (NSIC) or Ministry of Culture.
  5. **The EMD be submitted separately as under:**
    1. Tender inviting authority in the SUPERINTENDING ARCHAEOLOGIST, ARCHAEOLOGICAL SURVEY OF INDIA, AGRA CIRCLE, AGRA.
    2. Tender of the Purchase Order shall be Three years including maintenance.
  6. **Estimated Cost Of Tender:** Rs. 3,65,793.00 (RS. THREE LAKH SIXTY FIVE THOUSAND SEVEN HUNDRED NINETY THREE ONLY).
- Address for communication, are as given below: -

**Contact Details:**

<b>Contact Person</b>	<b>SUPERINTENDING ARCHAEOLOGIST</b>
<b>Address for communication</b>	<b>SUPERINTENDING ARCHAEOLOGIST, ARCHAEOLOGICAL SURVEY OF INDIA, The 22, Mall Road, Agra Circle, Agra</b>
	<b>e-mail –Circleagr.asi@gmail.com e-mail – Circleagr.asi@gov.in</b>
<b>Contact No.</b>	<b>0562- 2227261-63</b>

**NOTICE INVITING TENDER**

Tenders are hereby invited on behalf of the President of India. For execution of work under Estimated cost of Rs. 3,65,793.00 (RS. THREE LAKH SIXTY FIVE THOUSAND SEVEN HUNDRED NINETY THREE ONLY).

2. Tender document consisting of the detailed plans, complete specifications, the schedule of quantities of the various classes of work to be done, and the set of conditions of contract to be complied with by the person whose tenders may be accepted. The tender forms can be downloaded from our website- www.asi.nic.in and e-portal eprocure.gov.in from 15/11/2017 to 27/11/2017.

2 (a) The site of the work is available, or the site for the work shall be made/available in parts.

1. The Contractors should upload their tender documents online only at CPPP website: <https://eprocure.gov.in/eprocure/app>. up to 10:00 Hrs of 15/11/2017 which will be opened on dated 28/11/2017 at 15:30 hours.

2. The tender form can be downloaded from our website- www.asi.nic.in and e-portal eprocure.gov.in . The tenderer must attach a DD (issued on or before last date of selling the tender form) of Rs.500/ (Rupees Five hundreds only) as cost of tender form (Non-refundable) in favour of SUPERINTENDING ARCHAEOLOGIST, ARCHAEOLOGICAL SURVEY OF INDIA, AGRA CIRCLE, AGRA while tendering.

3. The time allowed for execute of the work will be 120 days which will be reckoned after fifteen days from the date of issue of order to commence work.

4. The contractors should quote in figures as well as in words the rate and amount tendered by them. The amount for each item should be worked out and the requisite totals given.

5. When the contractors signs a tender in an Indian Language the percentage above or below and the tendered amount in case of PWD form No.7 and the total amount tender in the case of PWD form No.7 and total amount tendered in the case of PWD form No.8 and should also be written in the same language. In a case of illiterate contractors the rates or the amounts tendered should be attested by a witness.

6. Issue of tender form will be stopped one days before the date fixed for opening of tenders.

7. Earnest money amounting of Rs. 9,145.00 ) only (unless exempted) in deposit at call received of scheduled bank guaranteed by the Reserve Bank of India must accompany each tender which is to be in sealed cover super scribed tender for PROVIDING RED SAND STONE RAMP AT AKBARS TOMB SIKANDRA, AGRA and addressed to Superintending Archaeologist, Archaeological Survey Of India, Agra Circle, 22 Mall Road, Agra.

8. The contractor whose tender is accepted (unless exempted ) will be required to be furnish by way of security deposit for the due fulfillment of his contract.

I) In the case of works costing upto Rs. 1,00,000/- to 10% of the estimated cost of work put to tender.

II) In the case of works costing more than Rs.1,00,000/- and upto 2,00,000/- to 10% on the first Rs.1,00,000/- and 7 % on the balance.

III) In the case of works costing more than Rs.2,00,000/-, 10% on the first Rs.1,00,000/-, 7 % on the next Rs. 1,00,000/- and 5% on the balance amount.

9. The security amount will be deposited by contractor in the form of FDR/CDR of any Nationalised Bank pledged to the Superintending Archaeologist, Archaeological Survey of India, Agra Circle, Agra. Earnest money deposited at the time of tender, will be treated as a part of the security deposit. The security amount will also be accepted in the shape of Government securities. Fixed deposit receipt and Guarantee bonds of schedule banks and State Bank of India will also be accepted for this purpose provided confirmatory advise is forthcoming from the Reserve Bank of India.

10. The right of acceptance of a tender will with SUPERINTENDING ARCHAEOLOGIST, ARCHAEOLOGICAL SURVEY OF INDIA, AGRA CIRCLE, AGRA who does not bind himself to accept the lowest tender and reserves to himself the authority to reject any or all of the tenders received without assignment of a reason. All tenders in which any of the prescribed conditions are not fulfilled or are incomplete in any respect are liable to be rejected.

11. Canvassing in connection with tenders is strictly prohibited and the tenders submitted by the contractors who resort to Canvassing will be liable to rejection.

12. All rates shall be quoted on the proper form of the tender alone.

13. The criteria for approval of the lowest tender is over all lowest one against the total cost of the all items in the tender schedule.

14. On acceptance of the tender, the name of the accredited representative(s) of the contractor who would be responsible for taking instructions from the Engineer in charge shall be communicated to the Engineer in charge.

15-Special care should be taken to write the rates in figures as well as in words and the amounts in figures only, in such a way that interposition is not possible. The total amount should be written both in figures and words. The case of figures, the world Rs. should be written before rupees and word (P) after the decimal figures e.g. 2.15 p and case of words the word (Rupees) should proceed and the word 'only' it should in variably upto decimal places. While quoting the area in the schedule of quantities the word only should be written closely following the amount and it should not be written closely following the amount and it should not be written in the next line.

16. The President of India does not bind himself to accept the lowest or any tender and reserves to himself the right of accepting the whole or any part of the tender and tenderer shall be bound to perform the same at the rates quoted.

17. Sales tax or any other or material in respect of this contracts shall be payable by the contractor and Government will not entertain any claim whatsoever in this respect.

18. The contractor must produce Income Tax clearances certificate and Permanent A/C Number (PAN) before the tender can be sold to him.

19. The Contractor shall not be permitted to tender for works in the ASI circle (responsible for award and execution of the contracts) in which his near relative is posted as an officer in any capacity between the grades of Superintending Engineer and Assistant (both inclusive). He shall also intimate the names of persons who are working with him in capacity or are subsequently employed by him and who are near relatives to any Gazetted officer in ASI or in the Ministry of Tourism and Culture by the contractor should render him liable to be removed from the approved list of contractors of this Department.

20. The tender of works shall remain open for acceptance for a period of ninety days from the date of opening of tenders. If any tender withdraws his tender before the said period or make any modifications in the terms and conditions of the tender, which are not acceptable to the department. Then the Government shall forfeit 100% of the said earnest money absolutely.

21. Contractors exempted from payment of Earnest money and Security Deposit in individual cases should attach with the tender an attested Copy of Competent authorities letter exempting them from the payment of Earnest Money and Security Deposit and should produce the original whenever called upon to do so.

22. The tender for the work shall not be witnessed by a contractor or contractors who himself/themselves has /have tendered or who may and has /have rendered for the same work. Failure to observe this condition would render of the contractors tendering as well as witnessing the tender liable to summary rejection.

Should this tender be accepted, I/we hereby agree abide by and fulfil all the terms and provisions of the said conditions annexed hereto so far as applicable and or in detail thereof to forfeit and pay to the President of India or his successor in office the sum of money mentioned in the said conditions.

A sum of Rs. \_\_\_\_\_ (Rupees \_\_\_\_\_) is herewith forwarded in F.D.R. vide No. \_\_\_\_\_ dated \_\_\_\_\_ as earnest money. If I /we fails to commence the work as specified in the above memorandum or is I/we fail to deposit the amount of security deposit specified against (ii) a in the above memorandum in accordance with the clause I of the said conditions of contract. I/we agree that the said President of India or his successor in office shall/without prejudice to any other right or remedy, shall be retained by him towards such security deposit. I/we further agree that the said President of India or his successor in office shall also be at liberty to cancel the acceptance of the tender if I / we fail to deposit security amount as aforesaid.

SIGNATURE AND ADDRESS OF CONTRACTOR:

PAN No. : Phone No. : Mob. No. :

Signature & address of witness to signature of tenderer.

1-  
2-

The above tender is hereby accepted by me on behalf of the President of India  
Dated the 20 17

Signature of the officer by whom  
THE TENDER IS ACCEPTED



GOVERNMENT OF INDIA

OFFICE OF SUPERINTENDING ARCHAEOLOGIST

ARCHAEOLOGICAL SURVEY OF INDIA

AGRA CIRCLE, AGRA

22 MALL ROAD, AGRA

PRICE OF TENDERS Rs. 500.00 TENDERS FOR EXECUTION OF WORK (CPWD-9 TENDER)

S.NO. \_\_\_\_\_

NAME & ADDRESS OF CONTRACTOR \_\_\_\_\_

DATE OF OPENING: 28/11/2017 at 15.30 Hrs. TENDER DOWNLOADED TILL 27/11/2017 at 15.00 Hrs.

NAME OF WORK: PROVIDING RED SAND STONE RAMP AT AKBARS TOMB SIKANDRA, AGRA.

I/We hereby tender for the President of India of the job work described in the under mentioned memorandum according to the specification within the times specified and at the rates specified therein subject to the conditions to the contractor: -

MEMORANDUM

(I) EARNEST MONEY Rs. 9,145.00

(II) SECURITY DEPOSIT RS. 25,290.00

(III) PAYABLE IMMEDIATE ON THE ACCEPTANCE OF THE TENDER (INCLUDING EARNEST MONEY DEPOSITED WITH THE TENDER) -----

(IV) PERCENTAGE TO BE DEDUCTED FROM BILL : (Income tax + Education tax + Surcharge liable)

(V) PLACE OF WORK- SIKANDRA, AGRA

Sl. No	Works details	Quantity		Rate (in words)	Total amount (in words)
	Providing Red sand Stone Ramp at Akbars Tomb Sikandra, Agra				
1.	Providing red sand stone ramp to facilitate the physically challenged person. The ramp will be designed 1:12 gradient keeping in view of the international standard. As design attached.	4.70	Cum		
2.	Providing and fixing line dressed 60 mm thick Red sand Stone slab for ramp having 12mm wide and 10mm deep grooving between 12cm. interval and fixed with araldite and cement mortar	38.61	Sqm		
		TOTAL			

Signature of Contractor



स्वच्छ स्मारक, स्वच्छ भारत,  
स्वच्छता हमारी जिम्मेदारी, जन-जन की भागीदारी

GOVERNMENT OF INDIA  
Office of the Superintending Archaeologist  
Archaeological Survey of India  
Agra Circle, 22 Mall Road, Agra 282001

**NOTICE INVITING TENDER**

The Superintending Archaeologist, Archaeological Survey of India, Agra Circle, Agra, on the behalf of the President of India, invites sealed tender for execution of work as per specification given below in sealed cover for the work Providing Red sand Stone Ramp at Akbars Tomb Sikandra, Agra from the approved/registered contractors of Archaeological Survey of India.

**Eligibility Criteria: -**

1. The Contractors should registered under the Department of C.P.W.D./ M.E.S./ P.W.D./ RAILWAYS/ASI.
2. The Contractor should have 2 years working experience in Archaeological Survey of India from the date of publication of this tender notice.
3. The eligible Contractors may upload their tender documents online only at CPPP website: <https://eprocure.gov.in/eprocure/app> upto 15:00 hours of 27/11/2017 which will be opened on dated 28/11/2017 at 15:30 hours.

**ESTIMATED COST Rs. 3,65,793.00**

**EARNEST MONEY Rs. 9,145.00**

The earnest money should be in the form of FDR drawn in favour of the "SUPERINTENDING ARCHAEOLOGIST, ARCHAEOLOGICAL SURVEY OF INDIA" drawn in Agra only of Canara Bank or any scheduled bank guaranteed by the Reserve Bank of India and enclose with the tender.

Time allowed for completion of work will be 90 days which will be reckoned after fifteen days from the date of issue of order. Tenders of the contractors who do not deposit earnest money in favour of the Superintending Archaeologist, Archaeological Survey of India, Agra Circle in the prescribed form will be liable to be summarily rejected

Conditions and tender forms can be downloaded from our ASI website [www.asi.nic.in](http://www.asi.nic.in) w.e.f. 15/11/2017 to 27/11/2017 upto 16:00 hours of each day.

Tender documents are available in the ASI website [www.asi.nic.in](http://www.asi.nic.in) and e-portal [eprocure.gov.in](http://eprocure.gov.in). The tenderer must attach the copy of DD of Rs. 500/ (Rupees Five hundreds only) as cost of tender form (Non-refundable) in favour of SUPERINTENDING ARCHAEOLOGIST, ARCHAEOLOGICAL SURVEY OF INDIA, AGRA CIRCLE and the EMD while uploading the tender. The original copy of tender cost & the EMD should be deposited in ASI, Agra Circle before the date of opening the tender.

**LIST OF EXECUTION OF WORK**

**NAME OF WORK: PROVIDING RED SAND STONE RAMP AT AKBARS TOMB SIKANDRA, AGRA.**

Sl. No.	Description of execution of work	Qty	
A	Execution of work		
1.	Providing red sand stone ramp to facilitate the physically challenged person. The ramp will be designed 1:12 gradient keeping in view of the international standard. As design attached.	4.70	Cum
2.	Providing and fixing line dressed 60 mm thick Red sand Stone slab for ramp having 12mm wide and 10mm deep grooving between 12cm. interval and fixed with araldite and cement mortar	38.61	Sqm

*Beawad*  
Superintending Archaeologist



स्वच्छ स्मारक, स्वच्छ भारत,  
स्वच्छता हमारी जिम्मेदारी, जन-जन की भागीदारी

## INSTRUCTIONS FOR ONLINE BID SUBMISSION

The Bidders are required to submit soft copies of their Bids electronically on the CPP Portal, using valid Digital Signature Certificates. The instructions given below are meant to assist the Bidders in registering on the CPP Portal, prepare their bids in accordance with the requirements and submitting their Bids online on the CPP Portal. More information useful for submitting online Bids on the CPP Portal may be obtained at: <https://eprocure.gov.in/eprocure/app>.

### REGISTRATION

- 1) Bidders are required to enrol on the e-Procurement module of the Central Public Procurement Portal (URL: <https://eprocure.gov.in/eprocure/app>) by clicking on the link "Online Bidder Enrolment" on the CPP Portal which is free of charge.
- 2) As part of the enrolment process, the Bidders will be required to choose a unique username and assign a password for their accounts.
- 3) Bidders are advised to register their valid email address and mobile numbers as part of the registration process. These would be used for any communication from the CPP Portal.
- 4) Upon enrolment, the Bidders will be required to register their valid Digital Signature Certificate (Class II or Class III Certificates with signing key usage) issued by any Certifying Authority recognized by CCA India (e.g. Sify / NCode / EMudhra etc.), with their profile.
- 5) Only one valid DSC should be registered by a Bidder. Please note that the Bidders are responsible to ensure that they do not lend their DSC's to others which may lead to misuse.
- 6) Bidder then logs in to the site through the secured log-in by entering their user ID / password and the password of the DSC / e-Token.

### SEARCHING FOR TENDER DOCUMENTS

- 1) There are various search options built in the CPP Portal, to facilitate Bidders to search active tenders by several parameters. These parameters could include Tender ID, Organization Name, Location, Date, Value, etc. There is also an option of advanced search for tenders, wherein the Bidders may combine a number of search parameters such as Organization Name, Form of Contract, Location, Date, Other keywords etc. to search for a tender published on the CPP Portal.
- 2) Once the Bidders have selected the tenders they are interested in, they may download the required documents / tender schedules. These tenders can be moved to the respective 'My Tenders' folder. This would enable the CPP Portal to intimate the Bidders through SMS / e-mail in case there is any corrigendum issued to the tender document.
- 3) The Bidder should make a note of the unique Tender ID assigned to each tender, in case they want to obtain any clarification / help from the Helpdesk.

### PREPARATION OF BIDS

- 1) Bidder should take into account any corrigendum published on the tender document before submitting their Bids.
- 2) Please go through the tender advertisement and the tender document carefully to understand the documents required to be submitted as part of the Bid. Please note the number of covers in which the bid documents have to be submitted, the number of documents - including the names and content of each of the document that need to be submitted. Any deviations from these may lead to rejection of the Bid.
- 3) Bidder, in advance, should get ready the Bid documents to be submitted as indicated in the tender document / schedule and generally, they can be in PDF / XLS / RAR / DWF/JPG formats. Bid documents may be scanned with 100 dpi with black and white option which helps in reducing size of the scanned document.
- 4) To avoid the time and effort required in uploading the same set of standard documents which are required to be submitted as a part of every Bid, a provision of uploading such standard documents (e.g. PAN card copy, annual reports, auditor certificates etc.) has been provided to the Bidders. Bidders can use "My Space" or "Other Important Documents" area available to them to upload such documents. These documents may be directly submitted from the "My Space" area while submitting a Bid, and need not be uploaded again and again. This will lead to a reduction in the time required for Bid submission process.

### SUBMISSION OF BIDS

- 1) Bidder should log into the site well in advance for bid submission so that they can upload the Bid in time i.e. on or before the Bid submission time. Bidder will be responsible for any delay due to other issues.
- 2) The Bidder has to digitally sign and upload the required bid documents one by one as indicated in the tender document.
- 3) Bidder has to select the payment option as "offline" to pay the tender fee / EMD as applicable and enter details of the instrument.
- 4) Bidder should prepare the EMD as per the instructions specified in the tender document. The original should be posted/couriered/given in person to the concerned official, latest by the last date of Bid submission or as specified in the tender documents. The details of the DD/any other accepted instrument, physically sent, should tally with the details available in the scanned copy and the data entered during Bid submission time. Otherwise the uploaded bid will be rejected.
- 5) Bidders are requested to note that they should necessarily submit their financial Bids in the format provided and no other format is acceptable. If the price Bid has been given as a standard BOQ format with the tender document, then the same is to be downloaded and to be filled by all the Bidders. Bidders are required to download the BOQ file, open it and complete the white coloured (unprotected) cells with their respective financial quotes and other details (such as name of the Bidder). No other cells should be changed. Once the details have been completed, the Bidder should save it and submit it online, without changing the filename. If the BOQ file is found to be modified by the Bidder, the Bid will be rejected.
- 6) The server time (which is displayed on the Bidders' dashboard) will be considered as the standard time for referencing the deadlines for submission of the Bids by the Bidders, opening of Bids etc. The Bidders should follow this time during Bid submission.
- 7) All the documents being submitted by the Bidders would be encrypted using PKI encryption techniques to ensure the secrecy of the data. The data entered cannot be viewed by unauthorized persons until the time of Bid opening. The confidentiality of the Bids is maintained using the secured Socket Layer 128 bit encryption technology. Data storage encryption of sensitive fields is done. Any Bid document that is uploaded to the server is subjected to symmetric encryption using a system generated symmetric key. Further this key is subjected to asymmetric encryption using buyers/Bid opener's public keys. Overall, the uploaded tender documents become readable only after the tender opening by the authorized Bid openers.
- 8) The uploaded tender documents become readable only after the tender opening by the authorized Bid openers.
- 9) Upon the successful and timely submission of Bids (i.e. after Clicking "Freeze Bid Submission" in the portal), the portal will give a successful Bid submission message & a Bid summary will be displayed with the Bid no. and the date & time of submission of the Bid with all other relevant details.
- 10) The Bid summary has to be printed and kept as an acknowledgement of the submission of the Bid. This acknowledgement may be used as an entry pass for any Bid opening meetings.

### ASSISTANCE TO BIDDERS

- 1) Any queries relating to the tender document and the terms and conditions contained therein should be addressed to the Tender Inviting Authority for a tender or the relevant contact person indicated in the tender.
- 2) Any queries relating to the process of online Bid submission or queries relating to CPP Portal in general may be directed to the 24x7 CPP Portal Helpdesk Mobile Number - +91 8826246593 Tel: The 24 x 7 Help Desk Number 0120-4200462, 0120-4001002.

**TENDER ACCEPTANCE LETTER**  
**(To be given on Company Letter Head)**

Date:

To,

\_\_\_\_\_  
\_\_\_\_\_  
\_\_\_\_\_

SUB: ACCEPTANCE OF TERMS & CONDITIONS OF TENDER.

**TENDER REFERENCE NO: 5/SKD/84/2017-2018/W**

**NAME OF TENDER / WORK: - PROVIDING RED SAND STONE RAMP AT AKBARS TOMB SIKANDRA, AGRA.**

Dear Sir,

1. I/ We have downloaded / obtained the tender document(s) for the above mentioned 'Tender/Work' from the web site(s) namely: for the work of PROVIDING RED SAND STONE RAMP AT AKBARS TOMB SIKANDRA, AGRA.
2. I/ We hereby certify that I / we have read the entire terms and conditions of the tender documents from Page No. -- to -- (including all documents like annexure(s), schedule(s), etc.), which form part of the contract agreement and I / we shall abide hereby by the terms / conditions / clauses contained therein.
3. The corrigendum(s) issued from time to time by your department/ organization to have also been taken into consideration, while submitting this acceptance letter.
5. I/ We do hereby declare that our Firm has not been blacklisted/ debarred by any Govt. Department/Public sector undertaking.
6. I/ We certify that all information furnished by our Firm is true & correct and in the event that the information is found to be incorrect/untrue or found violated, then your department/ organization shall without giving any notice or reason therefore or summarily reject the bid or terminate the contract, without prejudice to any other rights or remedy including the forfeiture of the full said earnest money deposit absolutely.

Yours Faithfully,

(Signature of the Bidder, with Official Seal)

Name of Estimate:- Providing Red Sand Stone Ramp at Akbar's Tomb, Sikandra, Agra

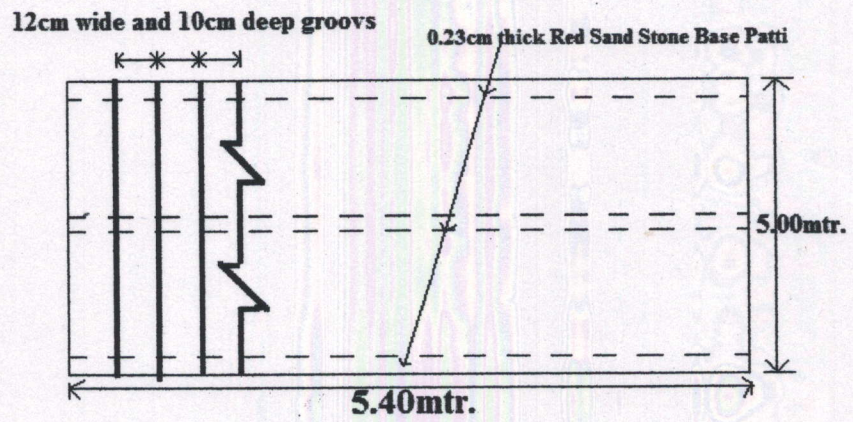
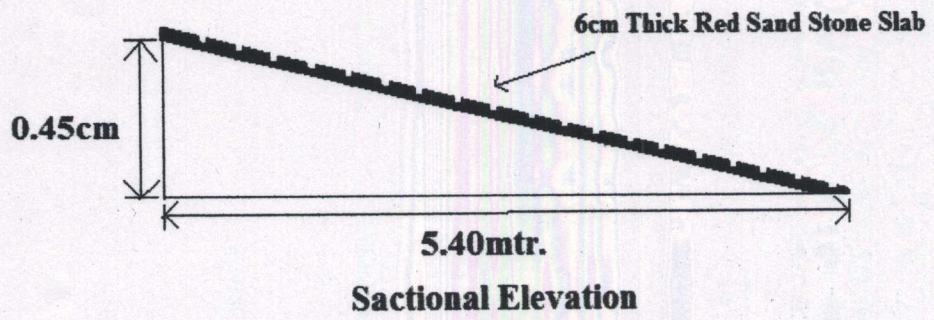

**Plan**

**Designen for 0.45cm heigh ramp**

**Not to the Scale**



**Name of Estimate:- Providing Red Sand Stone Ramp at Akbar's Tomb, Sikandra, Agra**

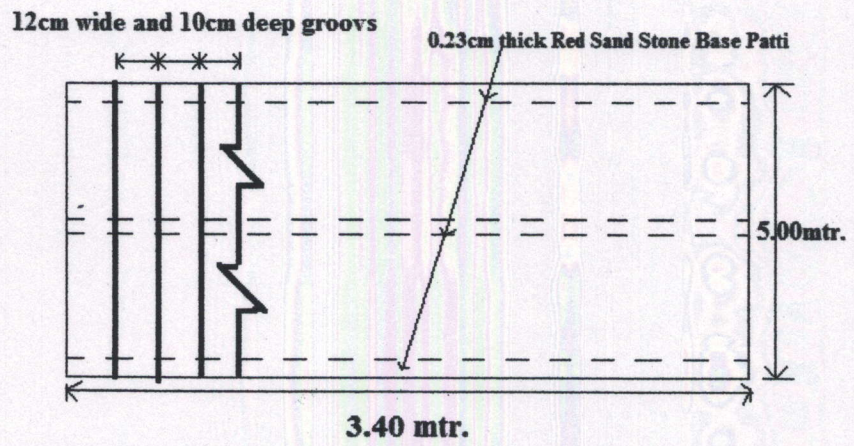
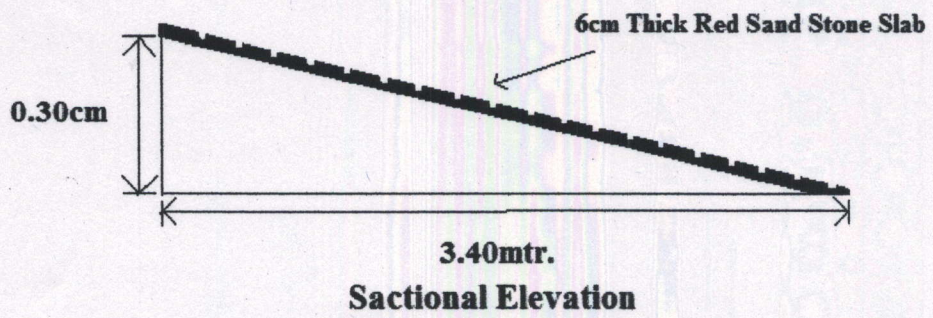

**Plan**

**Design for 0.30cm heigh ramp**

**Not to the Scale**

**Name of Estimate:- Providing Red Sand Stone Ramp at Akbar's Tomb, Sikandra, Agra**

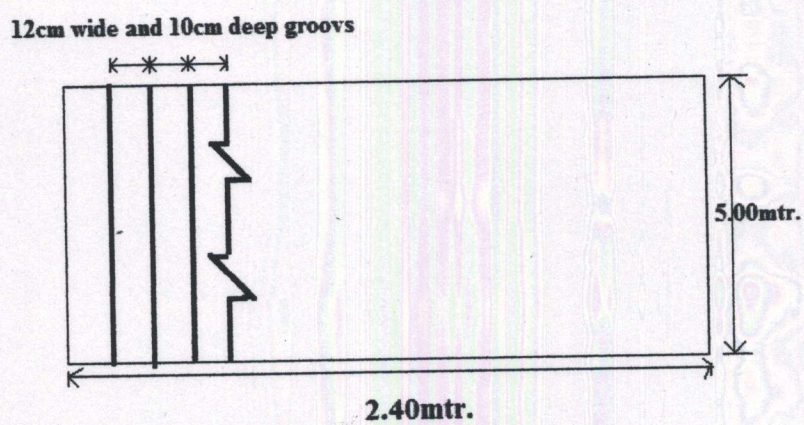
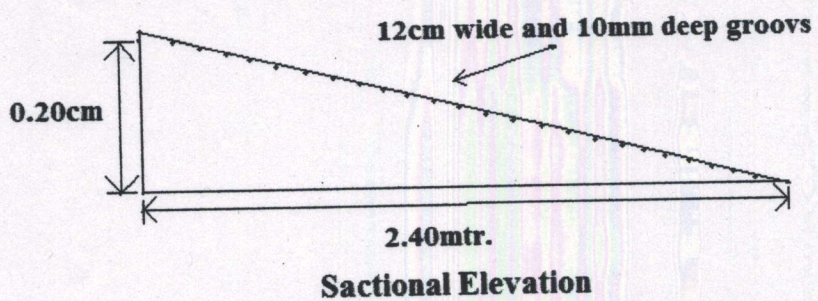

**Plan**

**Design for 0.20cm heigh ramp**

**Not to the Scale**